

**Il DRC MP CAN è il sistema di controllo remoto dei prodotti Audison bit dotati di ingresso DRCC.**

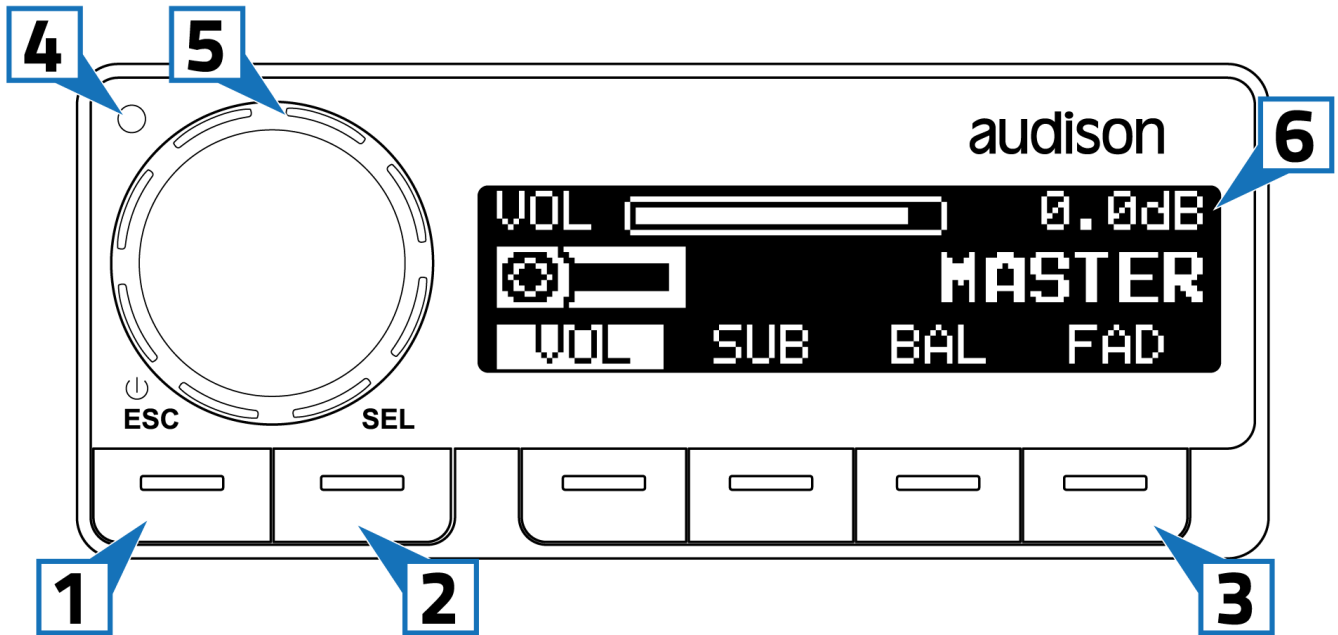

**1 POWER ON / Menu:** press the button to turn the system on ([see Ref. 6.1](#)), or switch it off by holding the button longer (3 sec.). This button enables the user to navigate the DRC MP CAN menus when the system is turned on.

**2 SEL:** through the “SEL” button you can select the input source of your audio system ([see Ref. 6.1](#)).

Note: If the amplifier is connected via ADC cable to another device (e.g. B-CON), switching the sources will NOT be possible with this button, but only using the B-CON go APP or automatically in the presence of streaming.

**3 Multifunction keyboard:** by default it enables the adjustment of the settings of FADER, BALANCE, SUB VOLUME and VOLUME.

**4 Brightness sensor:** the brightness sensor ([see Ref. 6.3](#)), which can be activated with the DISP BRIGHT and LED BRIGHT function, regulates the brightness intensity of the keyboard and display based on the ambient brightness. It is possible to deactivate the automatic Brightness adjustment function by setting the brightness to a value set by the menu.

**5 Encoder Joystick:** when used with a processor it enables the adjustment of the system FADER, BALANCE, SUB VOLUME by rotating the system master volume ([see Ref. 6.1](#)). When an Audison B-CON is connected to the processor, it is possible to control the player status with the Joystick ([see Ref. 6.3](#)).

**6** Alphanumeric display: OLED display 128 characters x 32 pixels.

**6.1 DEFAULT MENU'**

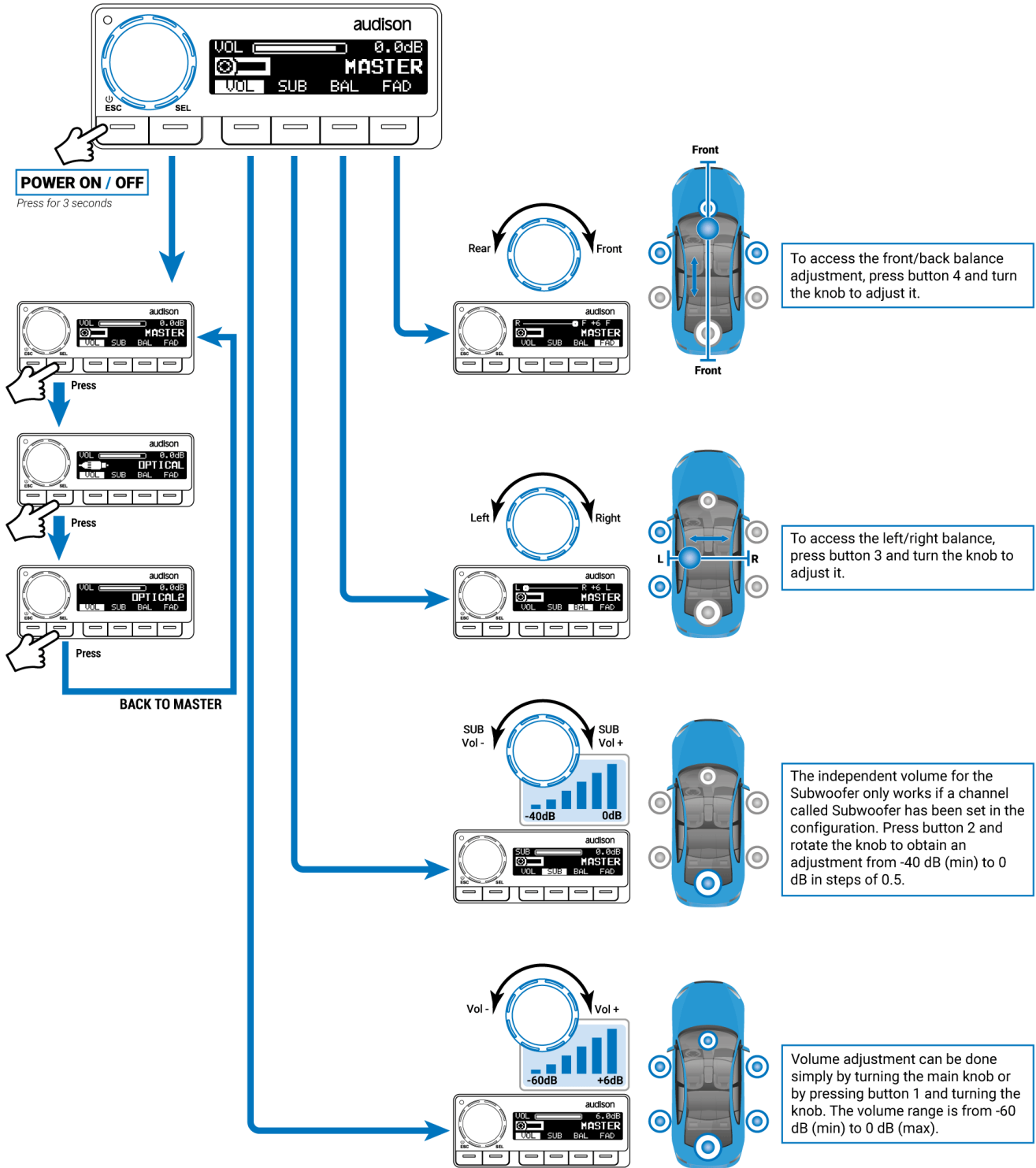

## 6.2 MEMORY

Allows to select the Preset memories programmed through the software bit Drive and stored in the processor.

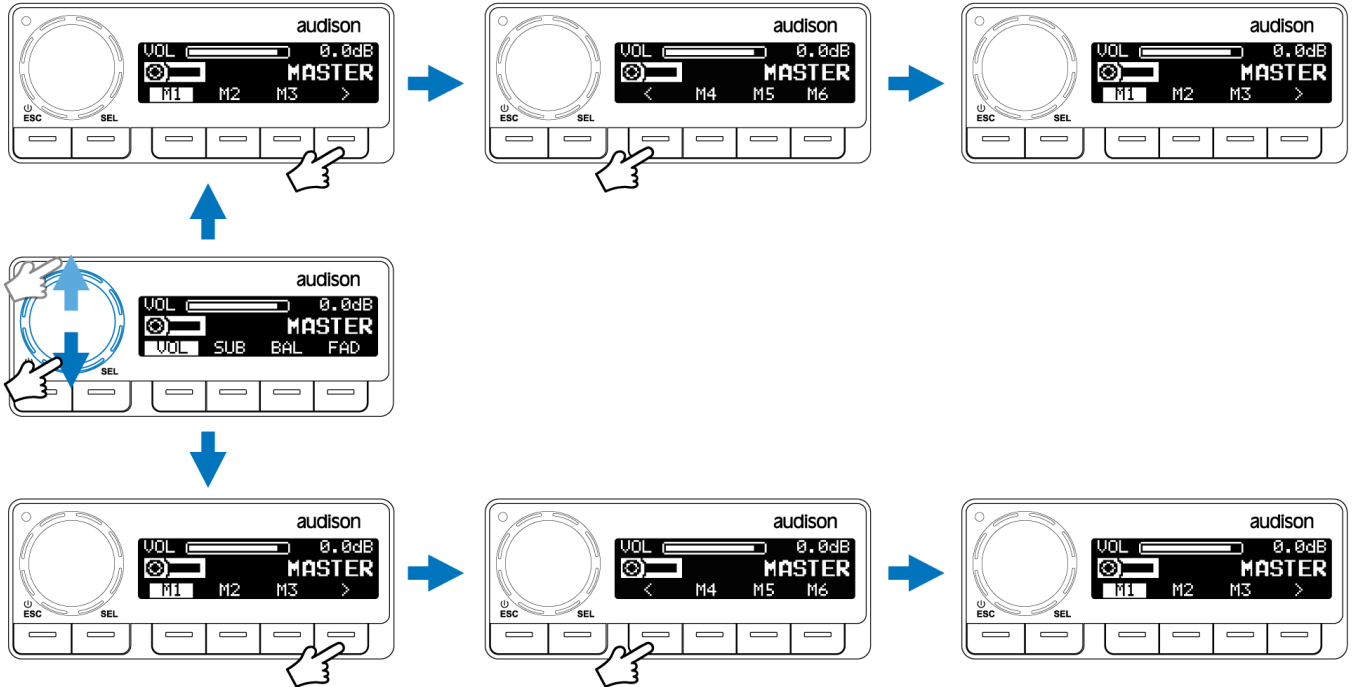

## 6.3 DRC MP CAN SETUP

Through this menu, the user can access the DRC MP CAN main settings like keyboard color, brightness, contrast, logo. It is also possible to check the product information such as serial number or firmware release.

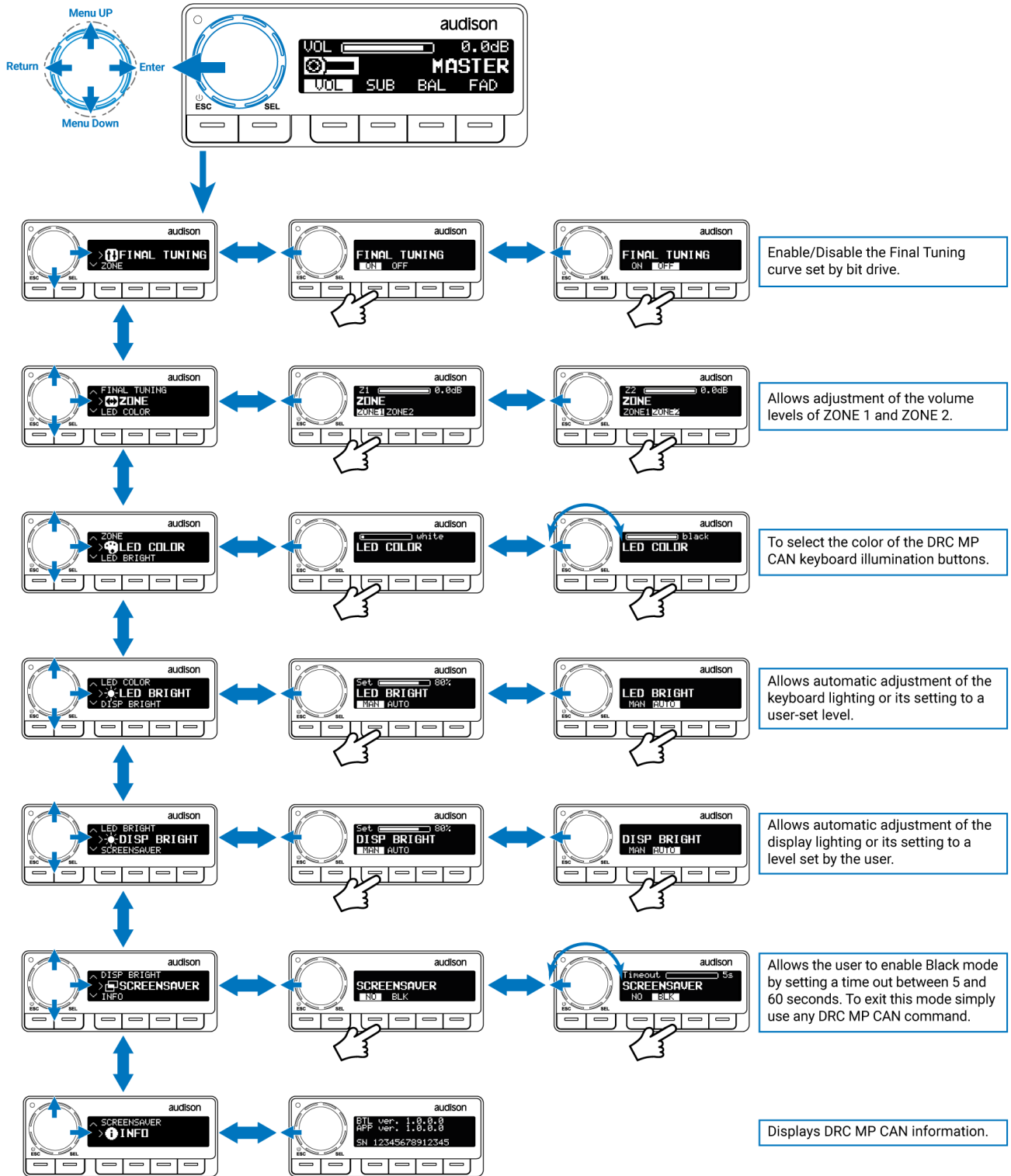

## 6.4 PLAYER MENU

This menu is only available if there is an Audison B-CON connected to the amplifier/processor via ADC cable.

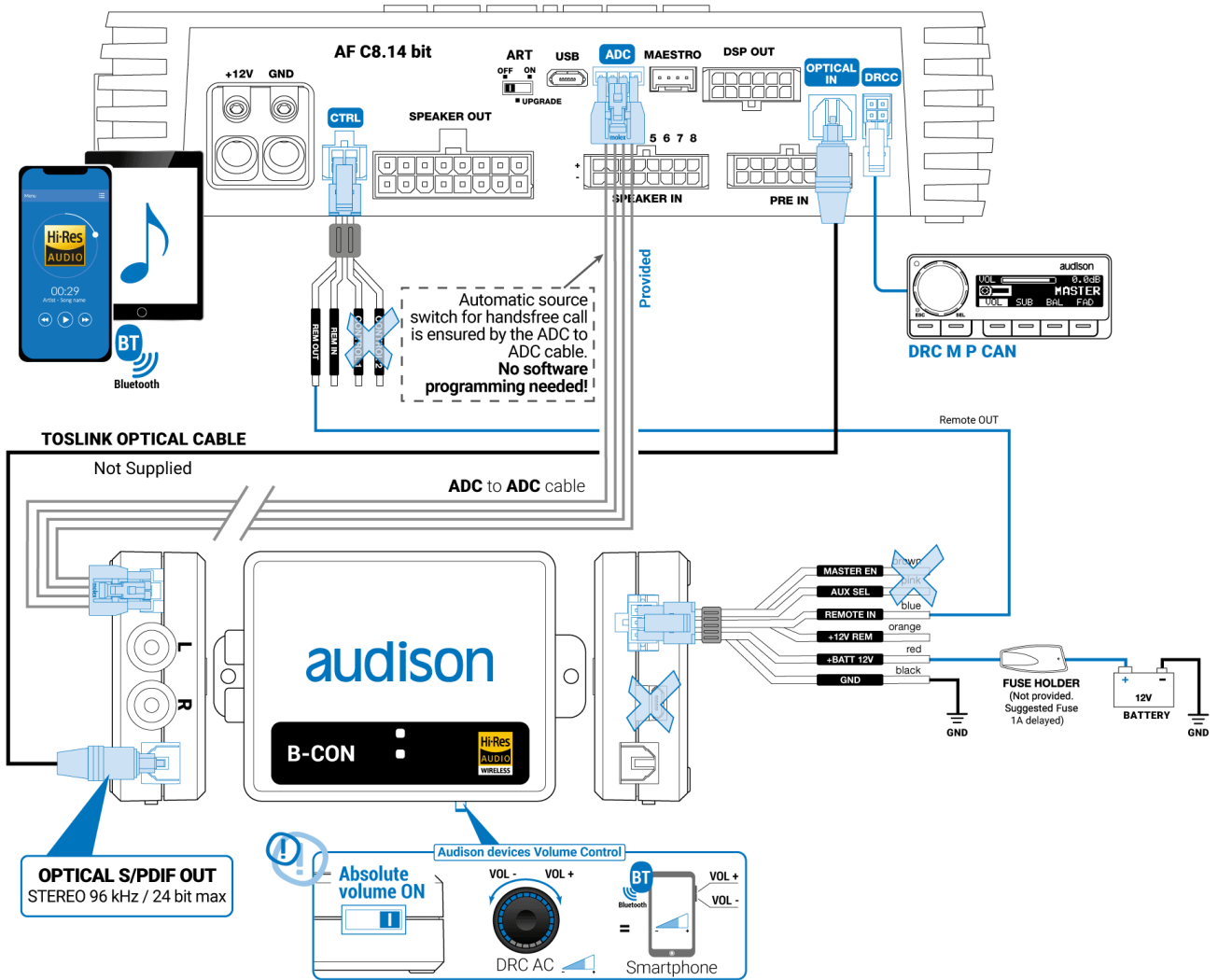

When the streaming starts from the B-CON, the main control commands of the player will be enabled on the DRC MP CAN display.

### 6.4.1 Streaming OFF

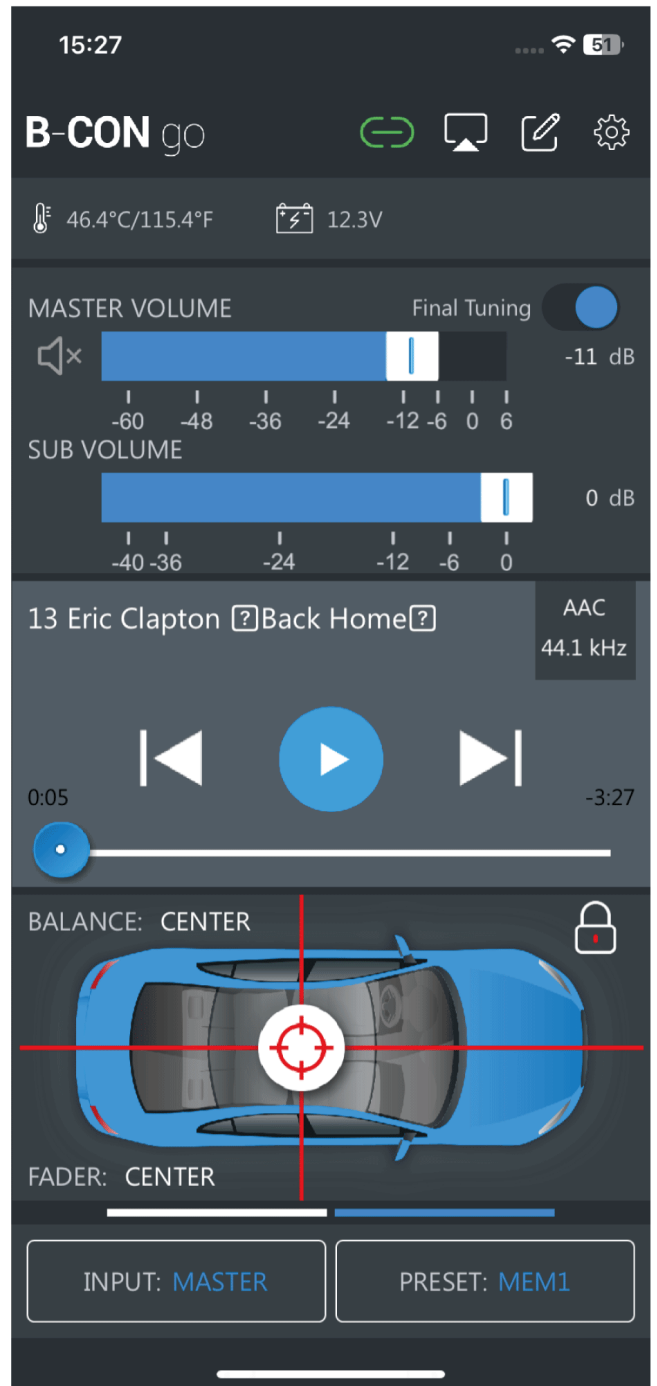
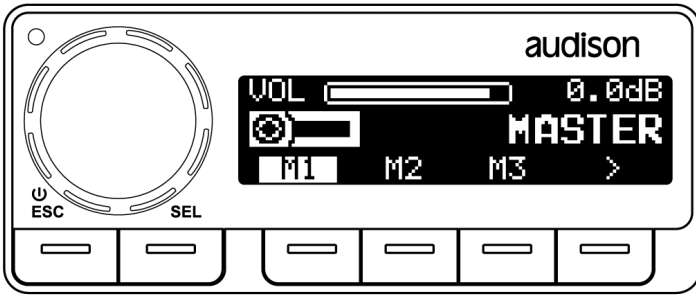

### 6.4.2 Streaming ON

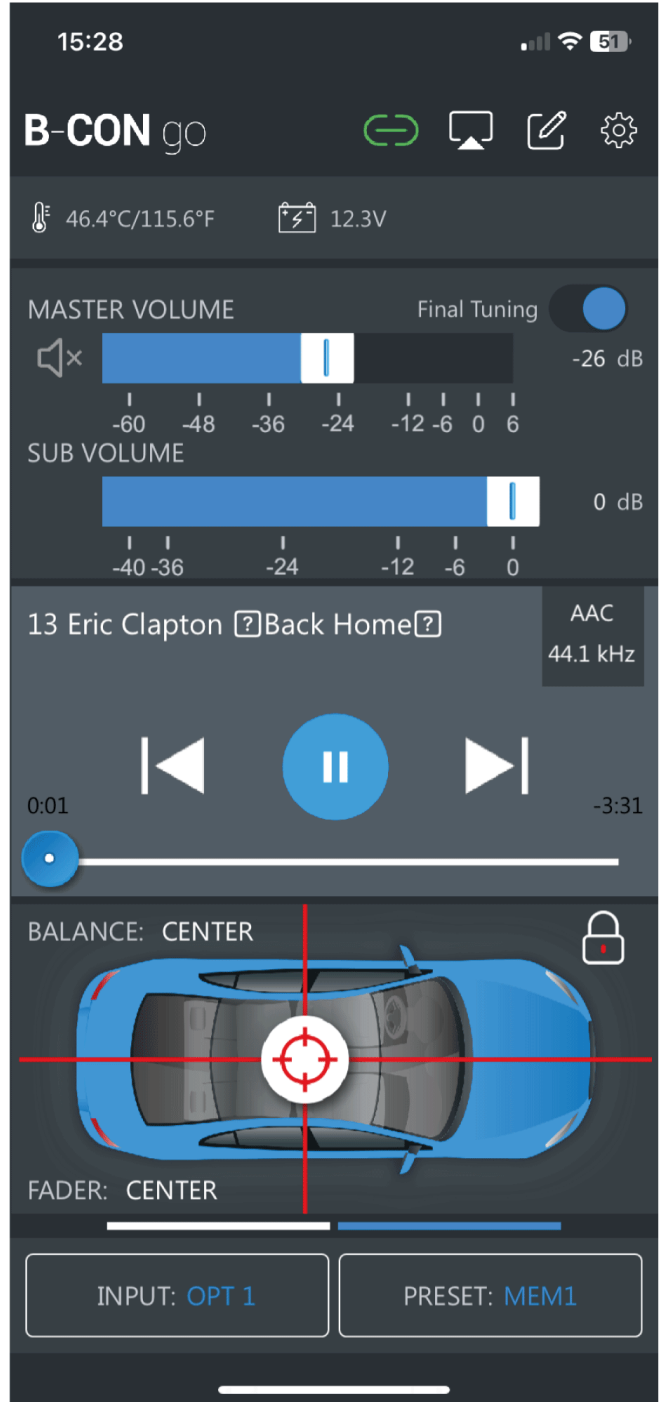
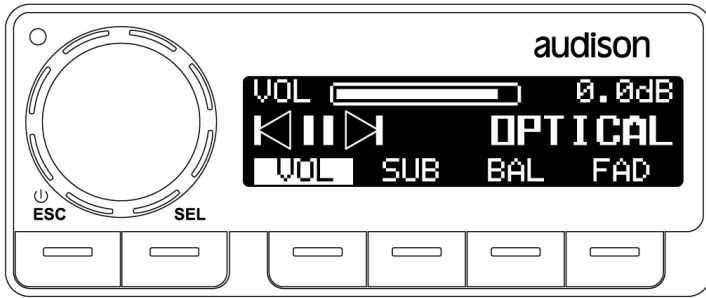

### 6.4.3 Next track

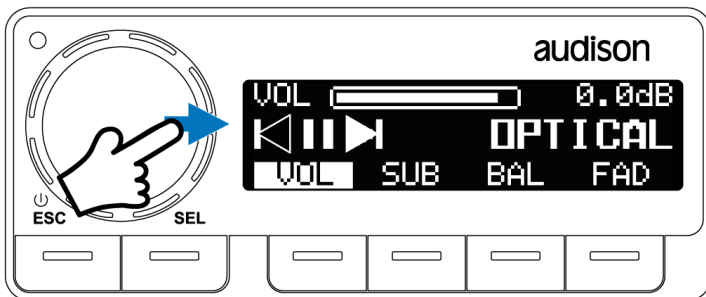

### 6.4.4 Previous track

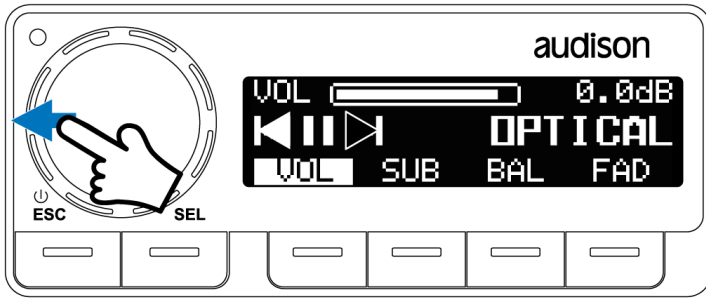

### 6.4.5 Pause

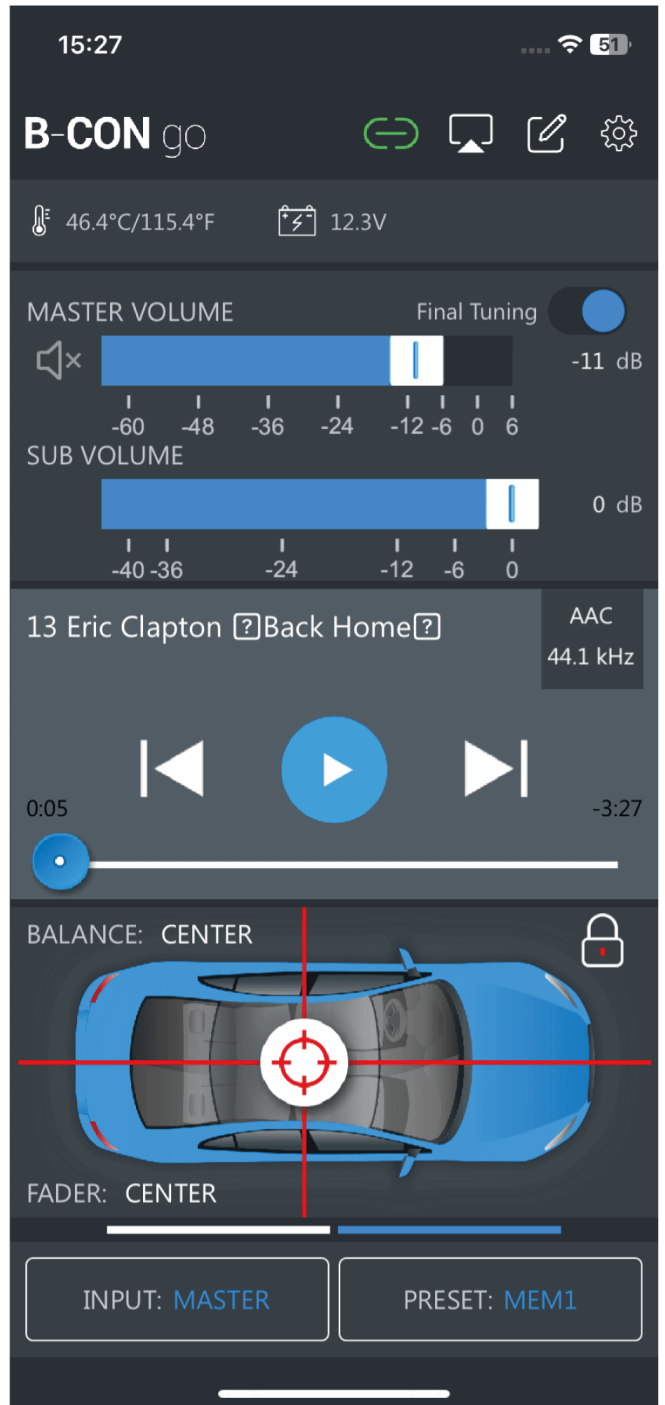
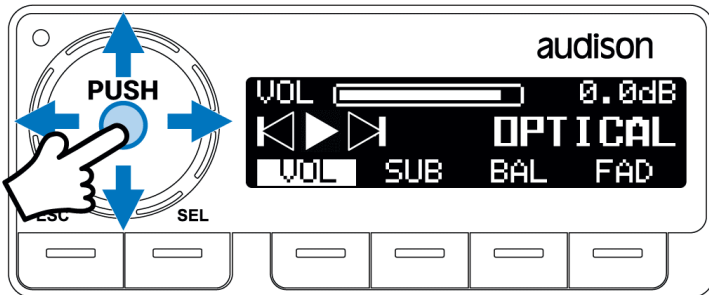



### 6.4.6 Play

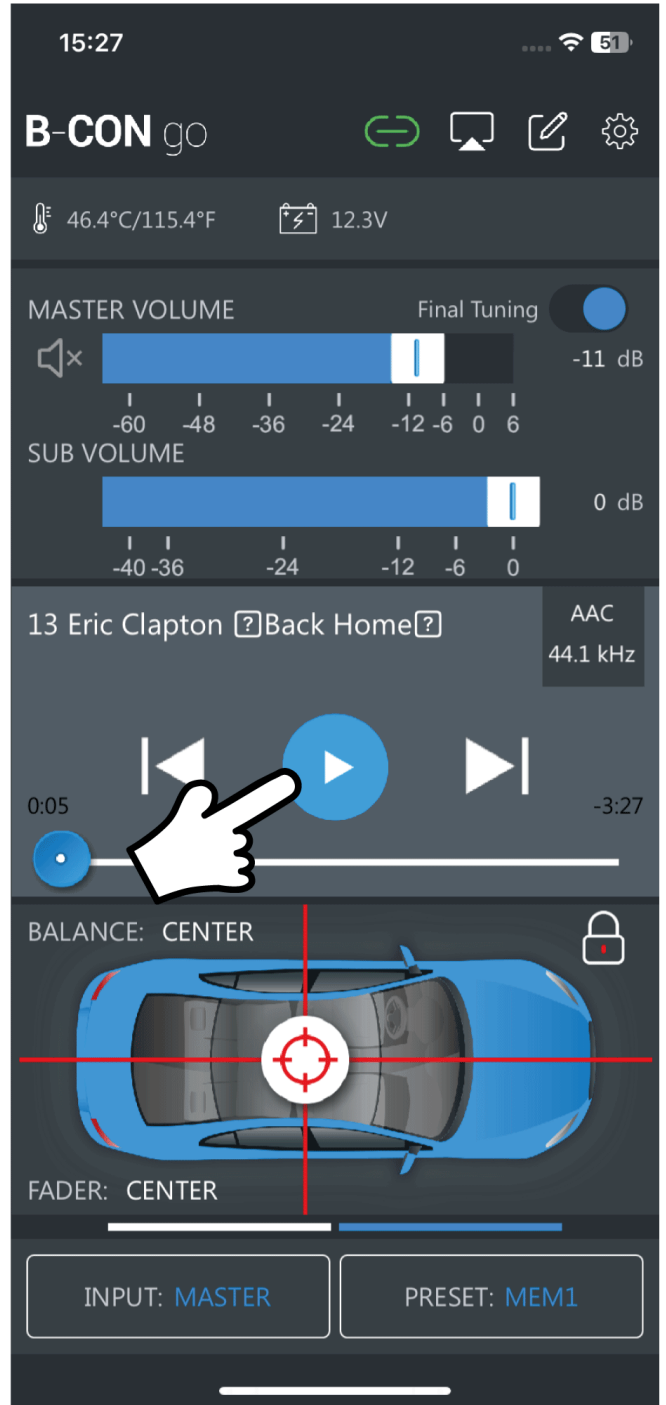

**Remark:** the streaming control commands can be used together with the **B-CON go APP** commands of the mobile device that is playing audio.